

VPM's
DR VN BRIMS, Thane
Programme: MMS (2015-17) (Operations)
Third Semester Examination October 2016

Subject	Materials Management & Transportation		
Roll No.		Marks	60 Marks
Total No. of Questions	7	Duration	3 Hours
Total No. of printed pages	2	Date	21.10.2016

Note: Q1 is compulsory and solve any FOUR from the remaining SIX questions.

Q1) 20 Marks (Compulsory)

Read the case study & answer the following questions:

LET'S PARTY!

"Let's party!" is still echoing in your head as you leave your Principles of Buying class. Again you ask yourself, "Why did I ever let myself run for class president?" Most of the people in the class were good, level-headed individuals who enjoyed a good time and you enjoyed working with them. But a small group from your class, who were known on campus as The Rowdies, often bullied their way on decisions affecting class activities. The decision to have a year-end party was right up their alley, and class had ended with a chanting session of "Let's party." It sounded like a wrestling match to you. Fortunately, your professor had left the room early to let you discuss with the class the idea of some kind of year-end get-together.

The Rowdies had immediately suggested the Goat's Ear, a local hangout with not much to offer but cheap drinks. The rest of your classmates had put forth some other suggestions, but no consensus on a location could be reached between the members of your executive committee or the rest of the class. If you went to the Goat's Ear most of the sane people in your class wouldn't attend, and even when you suggested more conventional locations, people couldn't agree because of factors such as the type of music played.

Since there were only two weeks left until the end of regular classes, you felt that you had to make arrangements in a hurry. It wasn't difficult to identify the most popular possible locations, but getting agreement from this group was going to be difficult.

One of your recent lectures was on supplier selection, and your professor had demonstrated the technique called the ranking or weighted-point method. It seemed simple enough in the lecture, and you had almost embarrassed yourself by asking the question "Why not just pick the least expensive supplier?" The thought occurred to you that there just might be some solution to your current problem in the professor's response, "One of the hardest things to do in any group, whether a business or a social club, is to get consensus on even the simplest choices."

Case Analysis

For this exercise, put yourself in the position of the class president described in this case and complete one of the two following exercises:

Exercise 1

1. Perform a supplier rating analysis for the situation. Include at least ten factors and four possible locations.
2. Make the selection as indicated by the analysis.
3. Discuss why the analysis led to your selection in step 2 and whether you would change any of the criteria or weights.

Attempt Any FOUR from the Remaining SIX Questions

Q2) Any two from (a) or (b) or (c) ————— (5x2) = 10 Marks

- a) What do you understand by integrated materials management?
- b) Explain vendor selection & evaluation process.
- c) Explain the process for letter of credit along with diagram.

Q3) Any two from (a) or (b) or (c) ————— (5x2) = 10 Marks

- Why is store location important? What are the principles of good location?
- Explain basic steps of MRP.
- What are the Steps in computerization for materials management?

Q4) Any two from (a) or (b) or (c) ————— (5x2) = 10 Marks

- What are the three types of box container? Explain in brief.
- Differentiate between obsolete, surplus & scrap. What are the reasons for the occurrence of obsolete items?
- Find item-wise material requirement for 50 "Product A"
Where on hand inventory for following items:
B-12, C-4, D-10, E-8, F-6

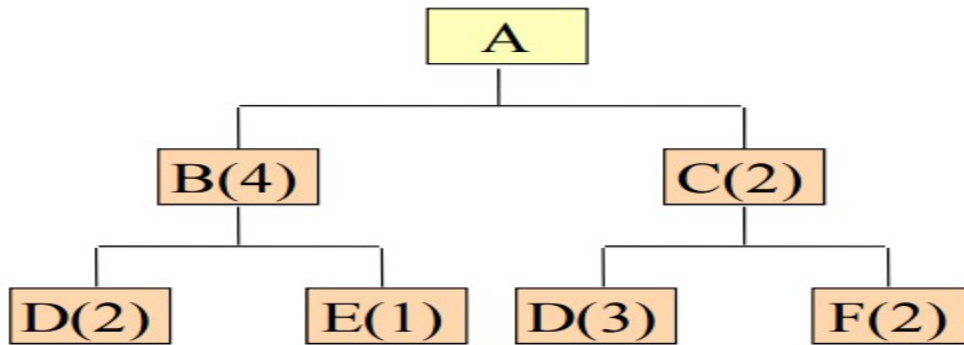

Q5) Any two from (a) or (b) or (c) ————— (5x2) = 10 Marks

- Explain costing of the issues to production for FIFO with one example.
- Explain Range of Buyer-Supplier Relationships.
- Explain the stages of disposal of material.

Q6) Any two from (a) or (b) or (c) ————— (5x2) = 10 Marks

- What are the different methods of codification of items? Explain them briefly.
- What factors influence the material planning?
- Explain material classification on following points:
 - Stage of conversion process
 - Nature of materials
 - Usability of materials

Q7) Any two from (a) or (b) or (c) ————— (5x2) = 10 Marks

- What do you understand from proper identification of materials? What are the different methods?
- What problems can arise if the co-ordination between finance & purchase is not adequate?
- Explain the following in brief:
 1. Bill of Entry
 2. Certificate of origin
 3. Bill of lading
 4. Import license
 5. Bill of sight